

INTERFACING

The model NC201 is supplied with a piece of double sided adhesive tape to eliminate the need for mounting hardware. When tuning of both code frequencies has been completed, remove the protective covering from one side of tape and attach it to the bottom side of P.C. board. Now remove protective cover from remaining side of tape and adhere unit to desired location, making sure that mounting surface is clean and dry to insure positive mounting. For maximum operational reliability, the decoder should be located away from intensive R.F. fields and all leads be kept to minimum lengths.

RED (+) [SUPPLY]	Connect to +5.5VDC to +24VDC.
BLACK (-)[SUPPLY]	Connect to system ground.
GREEN [DECODE AUDIO INPUT]	Connect DIRECT to receiver's discriminator.
GRAY [PTT CIRCUITRY]	Connect to transceiver circuitry that provides a "HIGH" (+ voltage), and goes "LOW" (to ground) when transmitter is activated. This function will provide the user of a portable radio upon a momentary push of the "PTT" switch to activate the decoders latched output circuitry, allowing monitoring of the channel.
BROWN [MONITOR/RESET]	Connect to microphone hang-up switch or hang-up button on back of microphone. If used for portable radio [Hand held] applications, then connect this lead to the tone/squelch switch. The monitor/Reset circuitry is factory selected to activate the latched output circuitry when high (above ground). To reverse this function, solder bridge jumper JU6 pads. If jumper pad JU6 is not soldered, and this lead is NOT used, it MUST be grounded.
BLUE [MOMENTARY OUTPUT]	Connect this lead to vehicle's horn relay. This output is an N-Channel power MosFet transistor, and will sink to ground when active, 100mA@40VDC. Note: <i>To prevent damage to MosFet device, place a IN4005 or equivalent diode across coil of horn relay.</i> This feature is factory selected as a steady output with a duration of 6 seconds. To change this feature to pulsed output, solder bridge jumper JU1 . To make this a latched output, until reset by [MONITOR/RESET] input, solder bridge jumper JU2 .
ORANGE [LATCHED OUTPUT]	Connect this lead to receiver's squelch circuitry to mute audio during stand-by. This output is an open collector transistor, and will sink to ground 100mA@40VDC. This feature is factory selected to provide a "LOW" (to ground) until receipt of a valid decode sequence, activation of monitor/reset or PTT inputs. To reverse output to a "HIGH" (above ground) remove solder bridge jumper JU8 .
BLUE WHITE [CALL LIGHT OUTPUT]	Connect to a LED indicator. This feature is factory selected to "SOURCE" +5VDC thru a series current limiting resistor of 1K OHM. To "SINK" this output solder bridge jumper JU7 .
VIOLET [TONE ALERT OUTPUT]	Connect to speaker HIGH terminal. This output is a "EMITTER FOLLOWER" with a series 47 OHM resistor. NOTE: <i>To use this output to drive receivers audio circuitry it will be necessary to D.C. couple this output (typically .01uF), and series a resistor (typically 100K OHM) to control audio level.</i>

**** SPECIFICATIONS ARE SUBJECT TO CHANGE IN THE INTEREST OF TECHNICAL IMPROVEMENT
WITHOUT NOTICE OR OBLIGATION.**

TUNING PROCEDURE

Adjustment of tone frequencies is easily performed. Each tone frequency is independently tunable through its specified range. The NC201 is factory pre-tuned as follows.

NC201-A: Tone 1 = 1800 Hertz, and Tone 2 = 1900 Hertz
 NC201-B: Tone 1 = 850 Hertz, and Tone 2 = 900 Hertz

CAUTION: Tone 1, and Tone 2 must have a frequency separation of 30 Hertz or greater in order to sequence filter between tones.

- [1] Connect **BLACK** lead to ground.
- [2] Connect **GRAY** lead (PTT) to ground.
- [3] Connect a wire from the pad labeled **FILTER** (filter output) on NC201 PCB to a Scope or A.C. RMS Voltmeter.
- [4] Connect **GREEN** lead (Tone input) to Audio generator.
- [5] Connect **RED** lead (+5 to +24 VDC) supply and apply power.
- [6] Remove **GRAY** lead from ground.
- [7] Set tone generator to tone 1 frequency.
- [8] Adjust multi-turn pot (R18) for typical indication of 1.25 VPP on scope, or 450 mV RMS on A.C. voltmeter.
- [9] Connect **GRAY** lead again to ground. This set filter to tone 2.
- [10] Set tone generator to tone 2 frequencies.
- [11] Adjust multi-turn pot (R19) for typical indication of 1.25 VPP on scope, or 450 mV RMS on A.C. voltmeter.
- [12] To exit tuning sequence, remove **RED** lead from power source and **GRAY** lead from ground.
- [13] Remove wire from **FILTER** pad to prevent shorting.
- [14] When power is applied, decoder will be enabled.

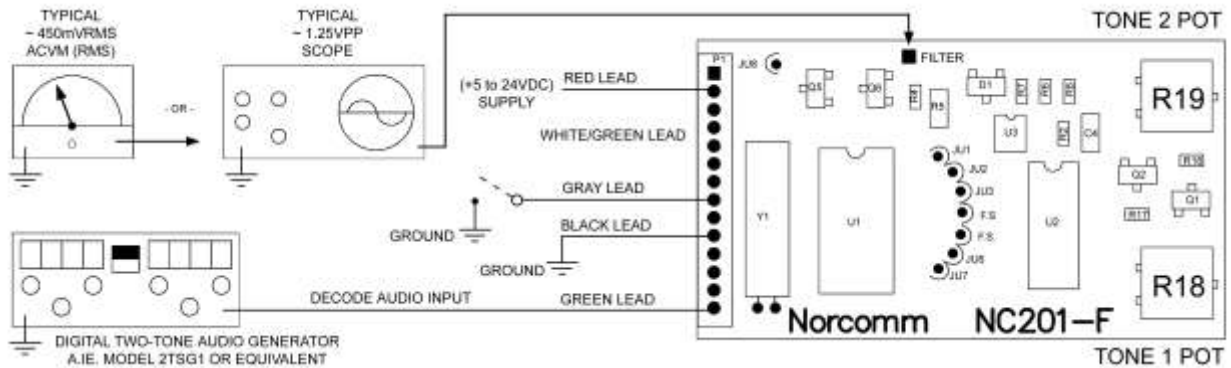

JUMPER CONFIGURATION CHART

JU3	JU6	MONITOR <i>Brown Wire</i>	PTT <i>Gray Wire</i>	LATCHED OUTPUT <i>Before Decode Orange Wire</i>	LATCHED OUTPUT <i>After Decode Orange Wire</i>
OUT	OUT	High	Activates Latched Output	JU8 IN = Open Collector	JU8 IN = Low
				JU8 OUT = High Imp.	JU8 OUT = +4.5 VDC
IN	OUT	High	Deactivates Latched Output	JU8 IN = Low	JU8 IN = Open Collector
				JU8 OUT +4.5 VDC	JU8 OUT = High Imp.
OUT	IN	Low	Activates Latched Output	JU8 IN = Open Collector	JU8 IN = Low
				JU8 OUT = High Imp.	JU8 OUT = +4.5 VDC
IN	IN	Low	Deactivates Latched Output	JU8 IN = Low	JU8 IN = Open Collector
				JU8 OUT = 4.5 VDC	JU8 OUT = High Imp.

SCHEMATIC

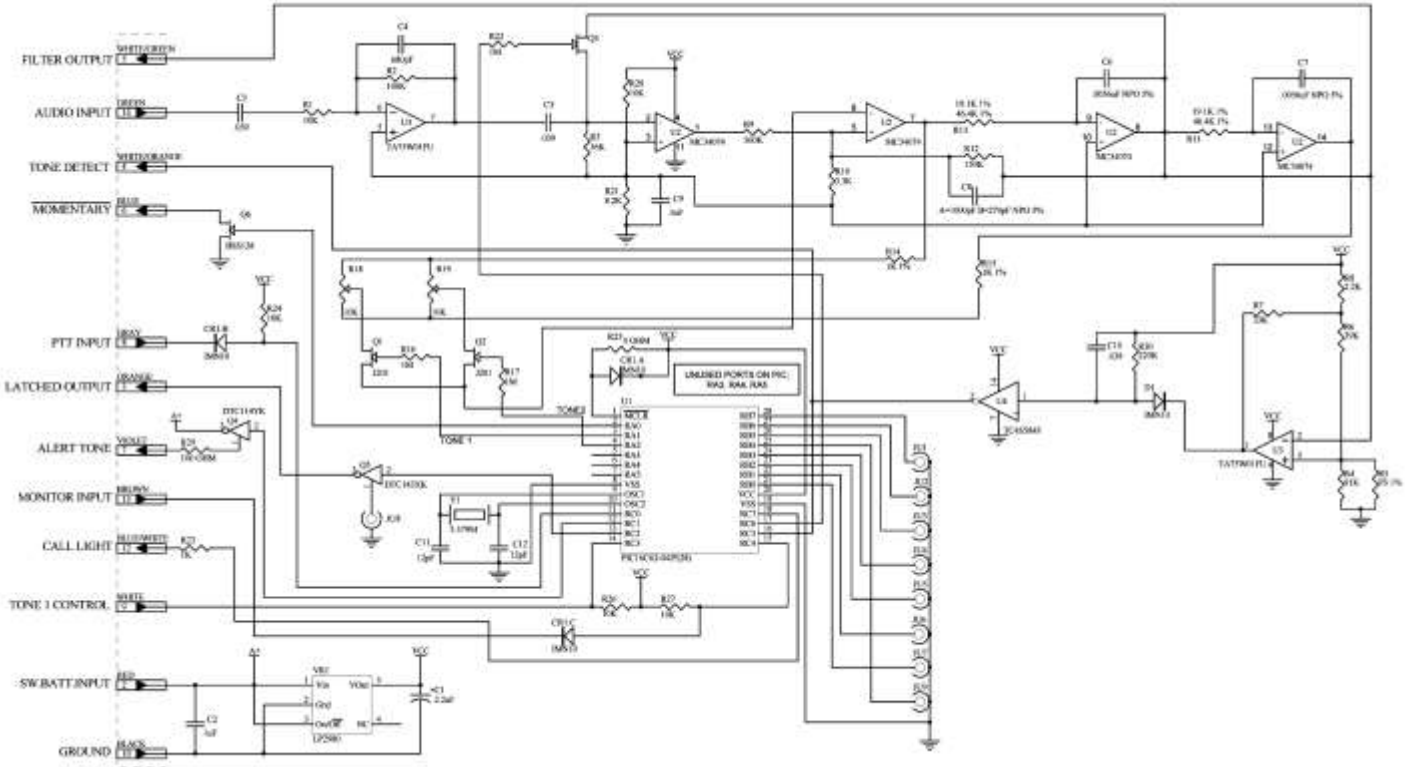

WARRANTY POLICY

NorComm products are unconditionally guaranteed for two (2) years on materials and labor from date of purchase.

All Warranty repairs must be performed at NorComm's Customer Service Department in Grass Valley, CA. Units under warranty can be returned for repair or replacement without prior authorization, however, a letter explaining the defect should be enclosed with the unit. Out of warranty units returned constitute Purchaser's authorization for NorComm to repair or replace equipment and to invoice Purchaser for any and all reasonable costs of repair labor, parts and freight and are returned COD.

NorComm shall not be obligated to repair or replace equipment rendered defective, in whole or in part, by causes external to the equipment, such as, but not limited to, catastrophe, power failure, or transients, environmental extremes, improper use, and maintenance or interfacing applications. NorComm further assumes no liability for any incidental or consequential damages which may result from the applications of its products by the Purchaser or any other party.